

HOW TO

CHOOSE AND

INSTALL A

CONDENSATE

REMOVAL

PUMP

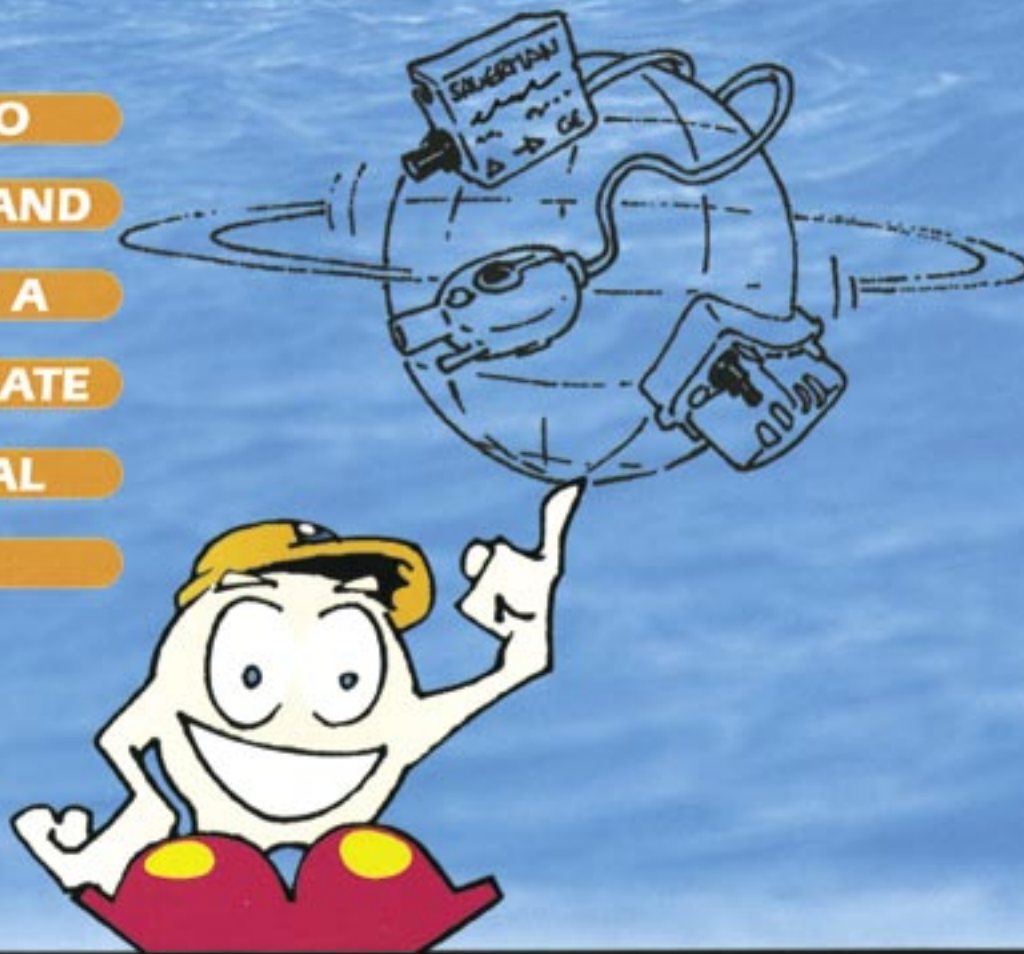

 **sauerermann™**

INSTALLER'S HANDBOOK

Definition GENERAL INFORMATION



► WHY?

► HOW?

The installation of air conditioning entails the formation of condensates (drops of water caused by the passage of warm moist air over the evaporator).

To get rid of them, there are **2** POSSIBILITIES:

1

Evacuate the condensates by gravity, which means dealing with technical and aesthetic difficulties (distant sanitation outlet, not enough fall damage to walls and ugly pipework)



2

Or - install a condensate removal pump (smaller size, the appearance of the installation is preserved, simple and quick to instal, safer as equipped with contact alarm and non-return valve)



▶ WHAT IS A CONDENSATE REMOVAL PUMP?

It is a system which consists of a **pump block** and a **detection unit** which means that, without a gravity fall, condensates are positively removed to the waste-water pipework.

This technology has **3 OVERWHELMING ADVANTAGES**:

- 1 It protects the appearance of the customer's installation (no ugly pipework to mark the site).
- 2 Ease, simplicity and safety of the installation.
- 3 Reduction of the risk of bacterial contamination by wastewater (no stagnation or back-flow of water thanks to non-return valves).

We propose **2 TYPES** of condensate removal pumps:

PISTON PUMPS

(Compound and monoblock)

SI 3100 & SI 3200

Max. flow rate:
2.6 gph / 5.3 gph
Max. suction head:
6.6 ft
Max. discharge head:
20 ft



SI 1102 & SI1200

Max. flow rate:
2.6 gph / 5.3 gph
Max. suction head:
0.0 ft
Max. discharge head:
20 ft



SI 1730

Max. flow rate:
8 gph
Max. suction head:
6.6 ft
Max. discharge head:
33 ft



CENTRIFUGAL PUMPS

(Monoblock with tank)

SI 1805 & SI 1820

Pump tank:
0.13 gal / 0.53 gal
Max. flow rate:
132 gph
Max. discharge head:
16 ft



► WHICH OPERATING MODE?

Whether monoblock or compound type, condensate removal pumps operate in **2 different ways**:

1) Reciprocating piston method

These pumps are fitted with a piston which first sucks in, then evacuates the condensate.

2) Centrifugal impeller method

A centrifugal impeller wheel evacuates the condensate. These pumps are intended for high flow rate requirements and are particularly suitable for "heavy" condensates.

► WHICH DETECTION SYSTEM?

SAUERMANN has developed 2 detection systems: **the first** is based on two individual float switches, one of which controls the **on/off** levels and the other the **alarm**.

SYSTEM INSTALLED ON THE
SI 1805 & SI 1820
CENTRIFUGAL PUMPS.

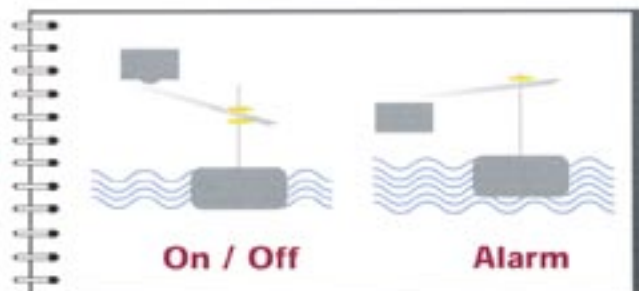

Definition GENERAL INFORMATION

The **second** is based on a float switch controlling 3 levels: **1 On, 2 Off, 3 Alarm**

SYSTEM INSTALLED ON THE
SI 3100/3200, SI 1102/1200, SI 1730

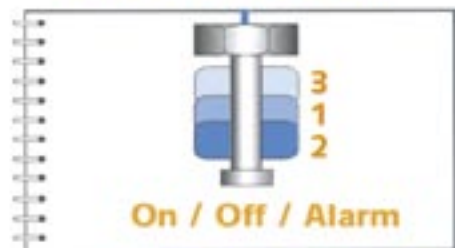

Because they are largely insensitive to the nature of the condensates (oily or greasy on the surface, deposits of tartar, dust or algae formation) **float switch detection** offers **great reliability**.

The presence of an alarm level makes a contribution to increased safety. As soon as a problem is detected (too much water arriving, etc.) the pump **automatically cuts off** the air conditioning system compressor or **sets off an audio or light alarm**.

Alarm levels of the various pumps

	SI 3100/3200	SI 1102/1200	SI 1730	SI 1805	SI 1820
ON	0.63 "	0.71"/0.94"	0.67"	0.94"	1.7"
OFF	0.44 "	0.47"/0.75"	0.44"	0.51"	1.1"
ALARM	0.75 "	0.83"/1.06"	0.83"	1.18"	2.64"

► HOW TO CHOOSE YOUR CONDENSATE REMOVAL PUMP



YOU NEED TO KNOW THE FOLLOWING CHARACTERISTICS:

- 1 **The volume of condensates produced** or the refrigerating capacity of your installation will give you an indication of the volume of condensates to be removed.
- 2 **The type of appliance** which you are equipping.

On the basis of these characteristics, you can choose your pump.
Check that the model you choose has a sufficient flow / pressure ratio.

WHICH PUMP

FOR WHICH APPLIANCE?



Air conditioning column units



Refrigerated display cabinets



Multi cassette systems



Ceiling suspended DX / Chilled water fan-coil units



Ducts units, consoles units

If you are in any doubt on which pump to choose, contact us!

Selection GENERAL INFORMATION

PUMP SELECTION GUIDE TABLE	SI 3100 SI 3200	SI 1102 SI 1200	SI 1730	SI 1805	SI 1820
WALL MOUNTED					
Split system	Ⓢ	Ⓢ			
Water-cooled consoles	Ⓢ	Ⓢ	Ⓢ		
Fan-coil units	Ⓢ	Ⓢ	Ⓢ		
Column units		Ⓢ	Ⓢ	Ⓢ	Ⓢ
CEILING MOUNTED					
Floor/ceiling suspended	Ⓢ	Ⓢ			
Ducted units	Ⓢ	Ⓢ	Ⓢ	Ⓢ	Ⓢ
Cassette & multi-cassettes				Ⓢ	Ⓢ
Units factory fitted with an internal pump with insufficient discharge height				Ⓢ	Ⓢ
REFRIGERATION					
Laboratory evaporators				Ⓢ	Ⓢ
Display cabinets				Ⓢ	Ⓢ
Cold-store evaporators				Ⓢ	Ⓢ
Ice-making machines				Ⓢ	Ⓢ
HEATING CONDENSING BOILERS				Ⓢ	Ⓢ



YOU MUST TAKE INTO ACCOUNT THE LOSS OF HEAD CONNECTED WITH:

- A** The **suction head** if the pump is installed higher than the air-handling unit
- B** The **vertical discharge head**
- C** The **total pipe length**

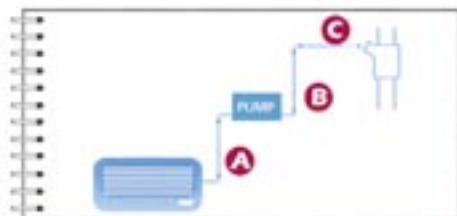

Selection GENERAL INFORMATION

THE REFRIGERATING CAPACITY GIVES YOU THE VOLUME OF CONDENSATES TO BE REMOVED

Use the cooling capacity information supplied by the manufacturer of the air-conditioner. It is generally estimated that, for normal usage conditions, the volume of condensates to be removed varies from **0.13 to 0.20 gal per kW of cooling capacity**.

For example : 3 kW of cooling capacity will produce from 0.40 to 0.63 gph of condensates to be removed.

In the case of Heat Pump (reverse cycle) appliances, you must ensure that the flow rate of the chosen pump is compatible with the volume of condensate produced during the de-frost cycles.

DETERMINE THE TRUE PUMP FLOW RATE RELATING TO YOUR INSTALLATION

For example - For example - For example

- One Air conditioner = 3 kW
- Volume to be removed : $3 \times 0.20 \text{ gal} = 0.60 \text{ gph}$
- Conditions of installation as follows:
 - A Suction head: 3.3 ft
 - B Vertical discharge head: 6.6 ft
 - C Total pipe length: 16.40 ft
- The right pump for these conditions is the: **SI3100**
(See table below)
- The true flow rate of your pump will therefore be: **1.58 gal**
(See table below)

Observation - Observation

True flow rate \geq volume of condensates to be removed

... You have chosen the right pump

True flow rate \leq volume of condensates to be removed...

... You must select a more powerful pump

Selection CHARACTERISTICS OF THE SI 3100 & SI 3200 PUMPS



SI 3100 & SI 3200 PUMPS TRUE FLOW RATES

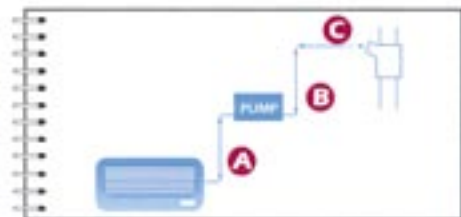

TABLE OF TRUE FLOW RATES FOR THE SI 3100 & SI 3200 PUMPS

The head losses defined in this table are calculated with 1/4" flexible pipework of 0.24" internal Ø

	Vertical discharge head	Total pipe length	16.40ft		32.80ftm		65.61ft		98.42ft	
			SI 3100 (gal/h)	SI 3200 (gal/h)	SI 3100 (gal/h)	SI 3200 (gal/h)	SI 3100 (gal/h)	SI 3200 (gal/h)	SI 3100 (gal/h)	SI 3200 (gal/h)
A SUCTION HEAD 0 ft	0 ft	3.3ft	2.51	5.02	2.38	4.62	2.16	4.09	1.95	3.56
		6.6ft	1.85	4.62	1.72	4.22	1.50	3.70	1.30	3.17
		9.8ft	1.32	4.23	1.21	3.70	1.03	3.17	0.90	2.64
		13.10ft	1.06	3.70	0.95	3.17	0.82	2.64	0.74	2.24
		16.40ft	0.85	3.04	0.71	2.64	0.66	2.24	0.60	1.85
		19.70ft	0.66	2.51	0.58	2.11	0.53	1.85	0.47	1.58
A SUCTION HEAD 3.3 ft	3.3 ft	3.3ft	1.98	4.36	1.85	4.09	1.64	3.56	1.42	3.17
		6.6ft	1.58	3.83	1.32	3.56	1.11	3.03	0.90	2.90
		9.8ft	1.27	3.30	0.92	3.04	0.76	2.77	0.66	2.64
		13.10ft	0.95	2.64	0.68	2.38	0.55	2.24	0.47	2.11
		16.40ft	0.58	2.25	0.45	1.98	0.4	1.71	0.34	1.45
A SUCTION HEAD 6.6 ft	6.6 ft	3.3ft	1.64	3.43	1.50	3.30	1.30	3.17	1.08	2.90
		6.6ft	1.32	3.17	1.19	3.04	0.98	2.90	0.76	2.64
		9.8ft	1	2.90	0.90	2.77	0.71	2.64	0.58	2.37
		13.10ft	0.63	2.11	0.52	1.98	0.40	1.85	0.31	1.58
		16.40ft	0.26	1.58	0.13	1.45	0.08	1.32	0	1.32
		19.70ft	0.13	1.05	0	0.92	0	0.80	0	0.80

Selection CHARACTERISTICS OF THE SI 1102 & SI 1200 PUMPS



SI 1102 & SI 1200 PUMPS TRUE FLOW RATES

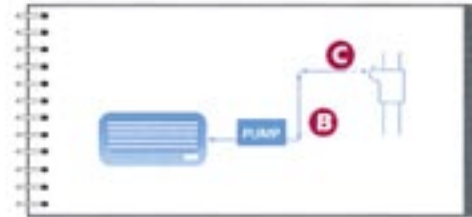

TABLE OF TRUE FLOW RATES FOR THE SI 1102 & SI 1200 PUMPS

The head losses defined in this table are calculated with 1/4" flexible pipework of 0.24" internal Ø	Vertical discharge head B	Total pipe length C	16.40ft		32.80ftm		65.61ft		98.42ft	
			SI 1102	SI 1200	SI 1102	SI 1200	SI 1102	SI 1200	SI 1102	SI 1200
			(gal/h)		(gal/h)		(gal/h)		(gal/h)	
	3.3ft	2.51	5.02	2.38	4.62	2.16	4.09	1.95	3.56	
	6.6ft	1.85	4.62	1.72	4.22	1.50	3.70	1.30	3.17	
	9.8ft	1.32	4.23	1.21	3.70	1.03	3.17	0.90	2.64	
	13.10ft	1.06	3.70	0.95	3.17	0.82	2.64	0.74	2.24	
	16.40ft	0.85	3.04	0.71	2.64	0.66	2.24	0.60	1.85	
	19.70ft	0.66	2.51	0.58	2.11	0.53	1.85	0.47	1.58	

Selection CHARACTERISTICS OF THE SI 1730 PUMP



SI 1730 PUMP TRUE FLOW RATES

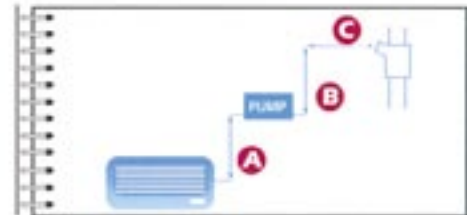

TABLE OF TRUE FLOW RATES FOR THE SI 1730 PUMP

The head losses defined in this table are calculated with 1/4" flexible pipework of 6mm internal Ø	Vertical discharge head	Total pipe length	16,40 ft	32,80 ft	65,61 ft	98,42 ft
			(in gal/h)	(in gal/h)	(in gal/h)	(in gal/h)
A SUCTION HEAD 0.0 ft	B 3,3 ft	C	6.5	6.0	5.45	4.95
	6,6 ft		5.2	4.95	4.7	4.42
	9,8 ft		4.4	4.42	4.16	3.9
	13,10 ft		3.6	3.64	3.4	3.12
	16,40 ft		3.4	3.38	3.12	2.86
	19,70 ft		2.6	2.34	2.08	1.82
A SUCTION HEAD 3.3 ft	3,3 ft		4.9	4.68	4.16	3.90
	6,6 ft		4.7	4.16	3.9	3.64
	9,8 ft		4.16	3.9	3.64	3.12
	13,10 ft		3.4	3.12	2.86	2.60
	16,40 ft		3.12	2.6	2.34	1.56
	19,70 ft		2.34	1.82	1.56	1.3
A SUCTION HEAD 6.6 ft	3,3 ft		4.16	3.9	3.64	3.4
	6,6 ft		3.9	3.64	3.38	3.12
	9,8 ft		3.64	3.12	2.86	2.6
	13,10 ft		3.12	2.6	2.34	2.08
	16,40 ft		2.34	2.08	1.82	1.56
	19,70 ft		1.56	1.3	1.04	0.8

Selection CHARACTERISTICS OF THE SI 1805, SI 1820 PUMPS

SI 1805 & SI 1820 PUMPS TRUE FLOW RATES

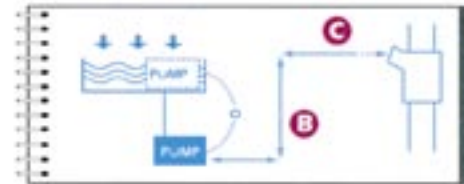

TABLE OF TRUE FLOW RATES FOR THE SI 1805 & SI 1820 PUMPS

The head losses defined in this table are calculated with flexible pipework of 0,39" internal Ø	Vertical discharge head	Total pipe length	16,40 ft	32,80 ft	65,61 ft	98,42 ft
			(in gal/h)	(in gal/h)	(in gal/h)	(in gal/h)
	3,3 ft		120	98.7	72.7	52
	6,6 ft		101.3	83.1	68.6	46.8
	9,8 ft		78	65	49.3	39
	13,10 ft		52	46.7	33.8	26
	16,40 ft		23.4	20.8	15.6	13



HOW TO INSTALL YOUR CONDENSATE REMOVAL PUMP

A FEW ESSENTIAL RULES

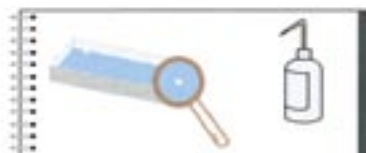

⇒ **Before installation**, thoroughly rinse the coil and the condensates collection tray to get rid of any foreign bodies and metal particles.



⇒ When the pump has a **separate detection unit**, it **MUST** be fixed **horizontally** on a flat surface.

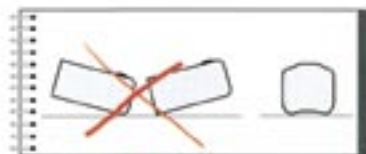

⇒ **Monoblock** tank pump must always be fitted **horizontally** on a level surface.

CAUTION

Before carrying out any operation on the pump, make sure the installation is disconnected from the electricity supply



Failure to observe these rules can lead to poor results, (tank overflow, high noise level, abnormal overheating etc.) which are both inconvenient for the end user and costly for the installer ! You are strongly advised to avoid the use of detergent or aggressive products on the tank of the **SI 1805** and **SI 1820** monoblock tank pumps.

OUTLINE DIAGRAM OF A TYPICAL SI 3100 & SI 3200 PUMPS INSTALLATION

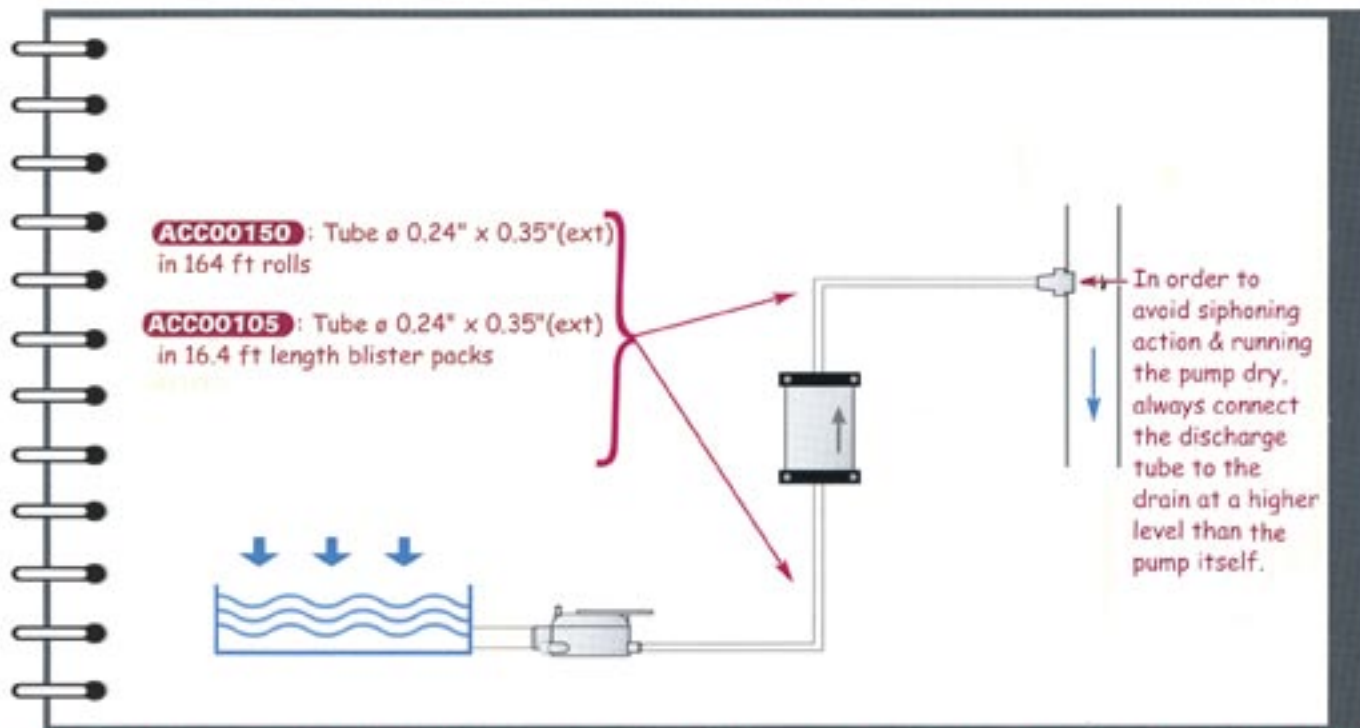

IMPORTANT COMMENT ON COMMISSIONING & MAINTENING SI 3100, SI 3200 AND SI 1730 PUMPS

To ensure that the pumps function correctly in the future, ensure that when you first commission them (and after each maintenance operation) the pumps are properly primed. In other words, ensure that the intake tube between that float detection unit and the pump itself is completely filled with water. For this you can use the **ACC 00401** priming squeeze bottle.



HOW TO INSTALL THE SAUERMANN SI 3100 & SI 3200 PUMPS

1 • The Detection Unit

Dimensions : L 2.2"x W 1.5"x H 1.3"

The detection unit can be connected in 3 ways

→ at the output from the condensate evacuation tube

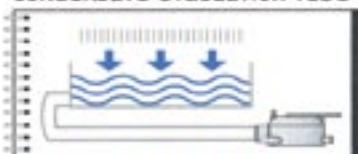

→ directly at the condensate drain tray outlet

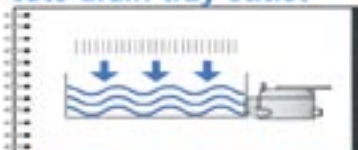

→ directly inside the condensate drain tray



Condensate can be drawn from either the **front** or the **back** of the detection unit to the pump.

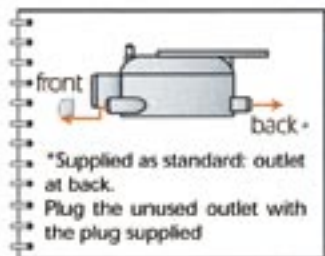

The vent pipe allows the air to be bled from the detection unit. You are advised to use the 0.16" clear tube supplied. Its length allows the upper level of the tube to be slightly above the maximum level of the condensates drain tray. In the event of an alarm or defect, this avoids overspill (principle of communicating vessels). When commissioning or after routine maintenance, ensure that this breather tube does not contain any water. Do not use a longer tube than the one supplied.

Installation position of the detection unit

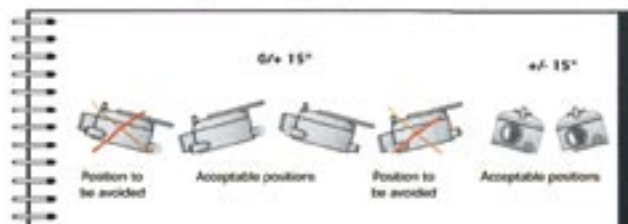

IMPORTANT

Make sure you clean the detection unit at every maintenance visit.



HOW TO INSTALL THE SAUERMANN SI 3100 & SI 3200 PUMPS



2 • The pump unit

Dimensions : L 2.6"x W 1.7"x H 2.4"

Ensure that the condensates pass through the pump in the **right direction** (see arrow provided)



The pump unit must **not be splashed with water** or be placed in a damp position.

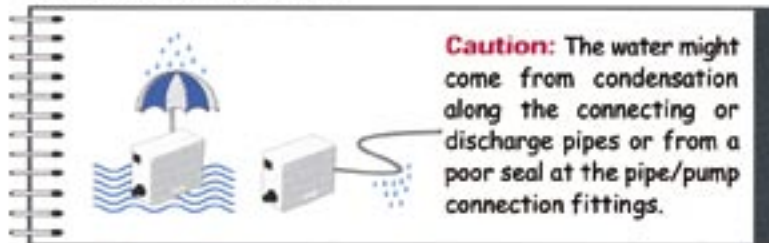

Caution: The water might come from condensation along the connecting or discharge pipes or from a poor seal at the pipe/pump connection fittings.

The **recommended fitting positions** for the pump are (avoid all other positions)

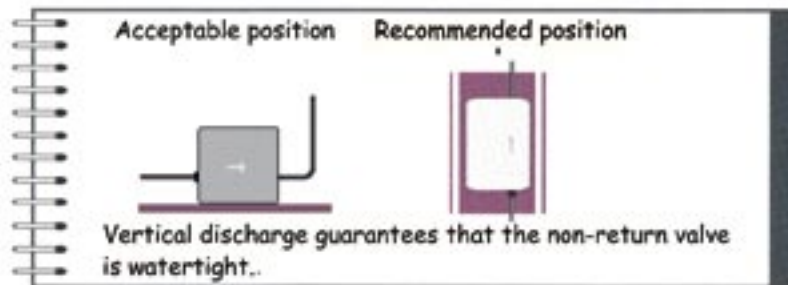

STARTING UP

Carry out an in situ test and prime the pump. To do this, gently fill with water using the priming squeeze bottle (ACC00401)

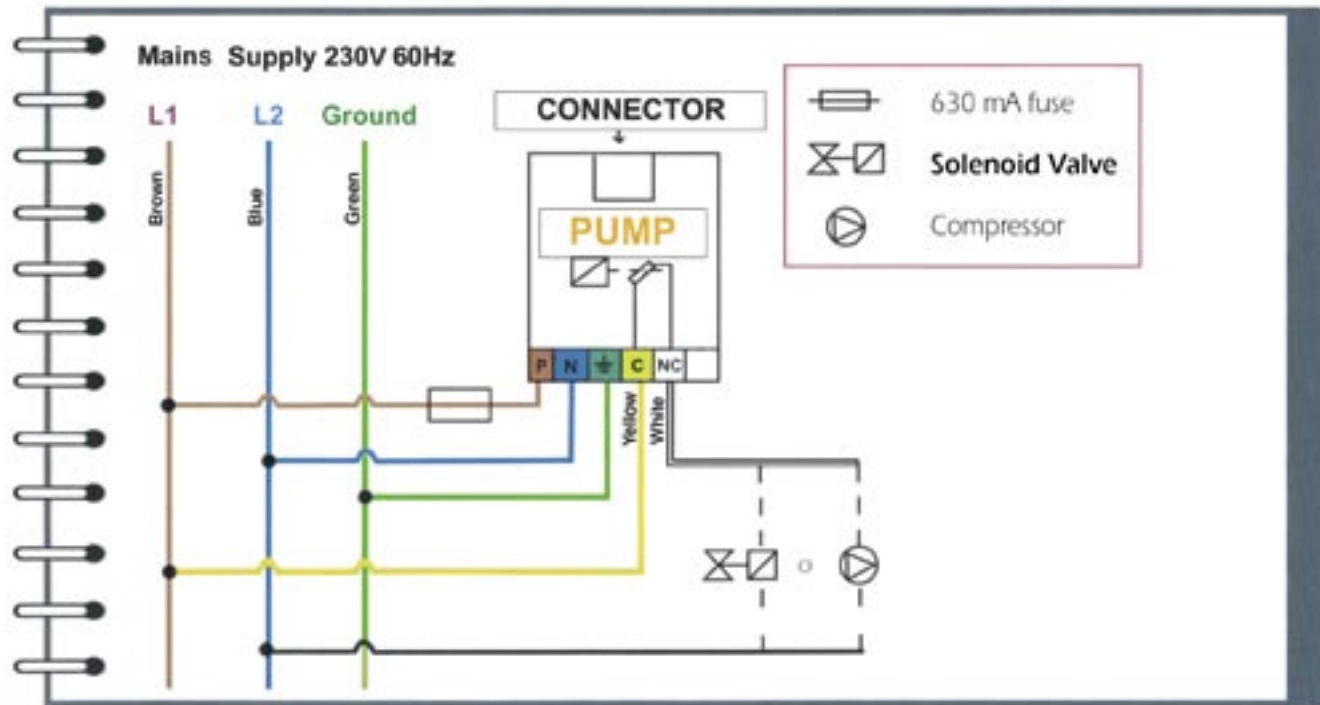

Diagram of electrical connections of the SI 3100/3200/1102/1200 PUMPS



IMPORTANT

The pumps must have an electricity supply that is independent to that of the air conditioner to ensure that they continue to operate if the refrigerating appliance breaks down.



Installation and Connection: SI3100/3200/1102/1200 PUMP - 120 V - 60 Hz

Diagram of electrical connections of the SI 3100/3200/1102/1200 PUMPS



IMPORTANT

The pumps must have an electricity supply that is independent to that of the air conditioner to ensure that they continue to operate if the refrigerating appliance breaks down.

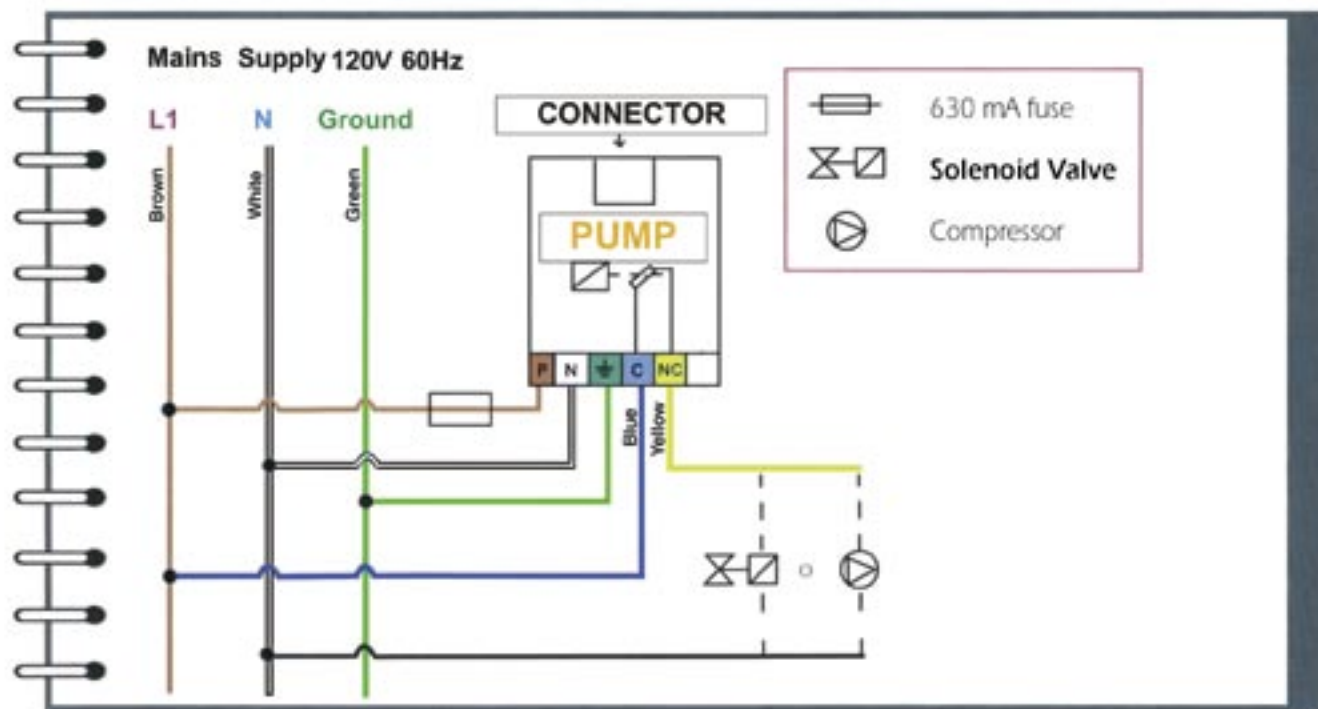

HOW TO INSTALL THE SAUERMANN SI 1730 PUMP



1 • The Detection Unit Dimensions : L 2.1"x W 1.6"x H 1.4"

The detection unit can be connected in 3 ways

⇒ at the output from the condensate drain tube

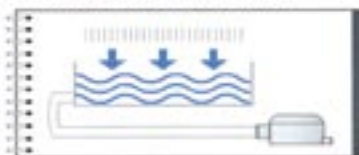

⇒ directly at the condensate drain tray outlet

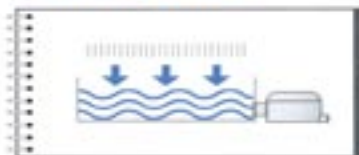

⇒ directly inside the condensate drain tray

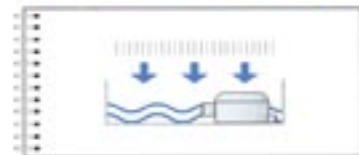

Installation position of the detection unit.

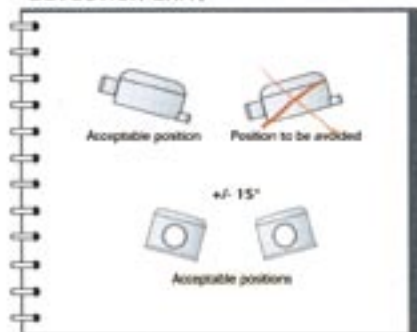

Make sure you clean the detection unit at every maintenance visit.

The vent pipe allows the air to be bled from the detection unit. You are advised to use the 0.16" clear tube supplied. Its length allows the upper level of the tube to be slightly above the maximum level of the condensates drain tray. In the event of an alarm or defect, this avoids overspill (principle of communicating vessels). When commissioning or after routine maintenance, ensure that this breather tube does not contain any water. Do not use a longer tube than the one supplied.

HOW TO INSTALL THE SAUERMANN SI 1730 PUMP

2• The pump unit

Dimensions : L 3.7"x W 2.9"x H 2"



Ensure that the condensates pass through the pump **in the right direction** (arrow on the case)

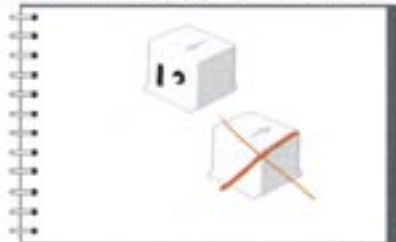

The pump unit **must not be splashed with water** or be placed in a damp position.

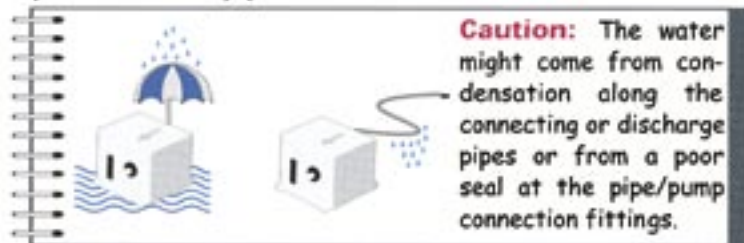

Caution: The water might come from condensation along the connecting or discharge pipes or from a poor seal at the pipe/pump connection fittings.

The **recommended fitting positions** for the pump are (avoid all other positions)

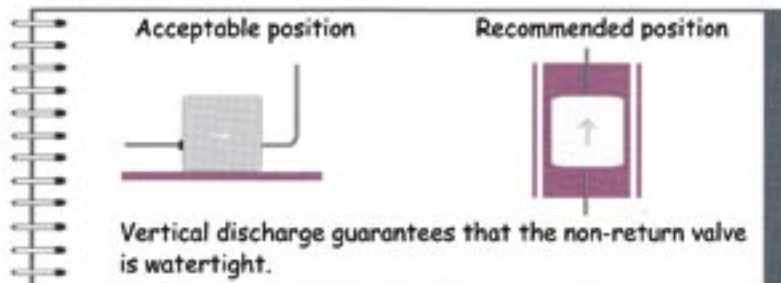

STARTING UP

Carry out an in situ test and prime the pump
To do this, gently fill with water using the priming squeeze bottle (ACC0040!)



5 • Diagram of electrical connections of the SI 1730 pump



IMPORTANT

The pumps must have an electricity supply that is independent to that of the air conditioner to ensure that they continue to operate if the refrigerating appliance breaks down.

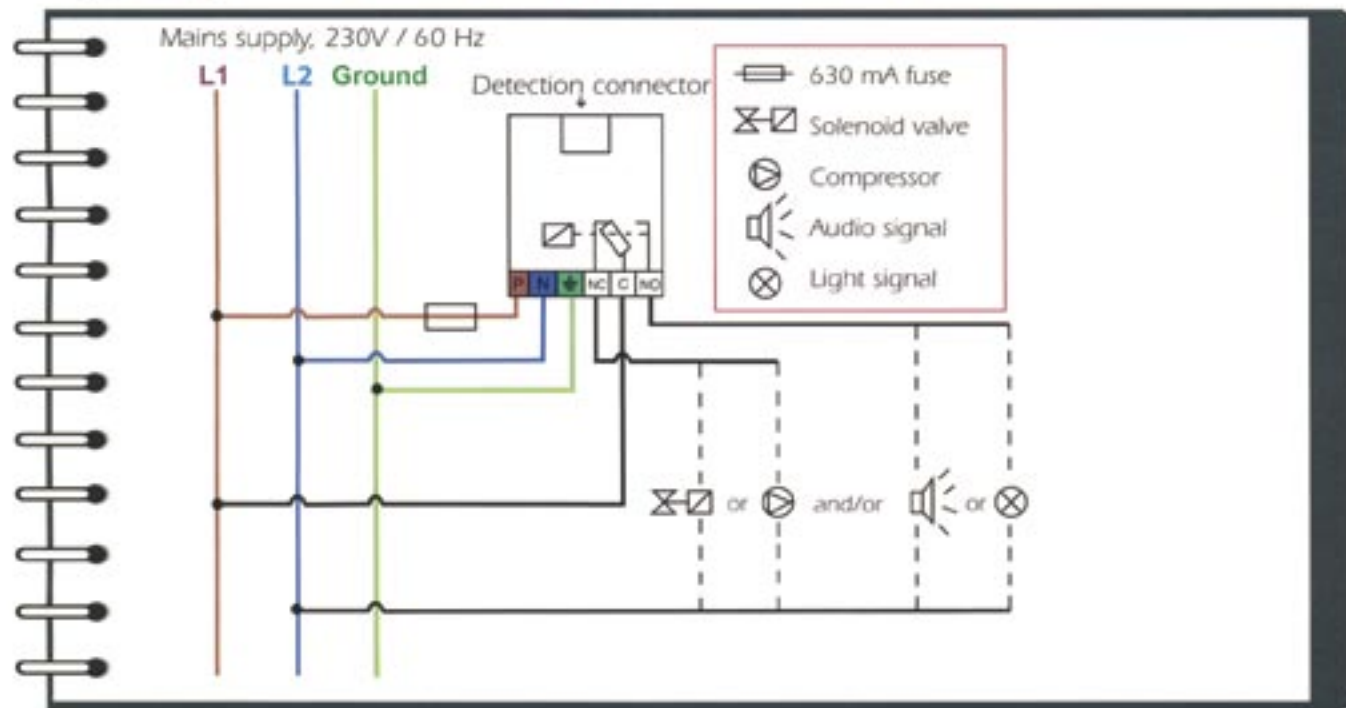

Installation and Connection: SI 1730 PUMP 120 V - 60Hz

5 • Diagram of electrical connections of the SI 1730 pump



IMPORTANT

The pumps must have an electricity supply that is independent to that of the air conditioner to ensure that they continue to operate if the refrigerating appliance breaks down.

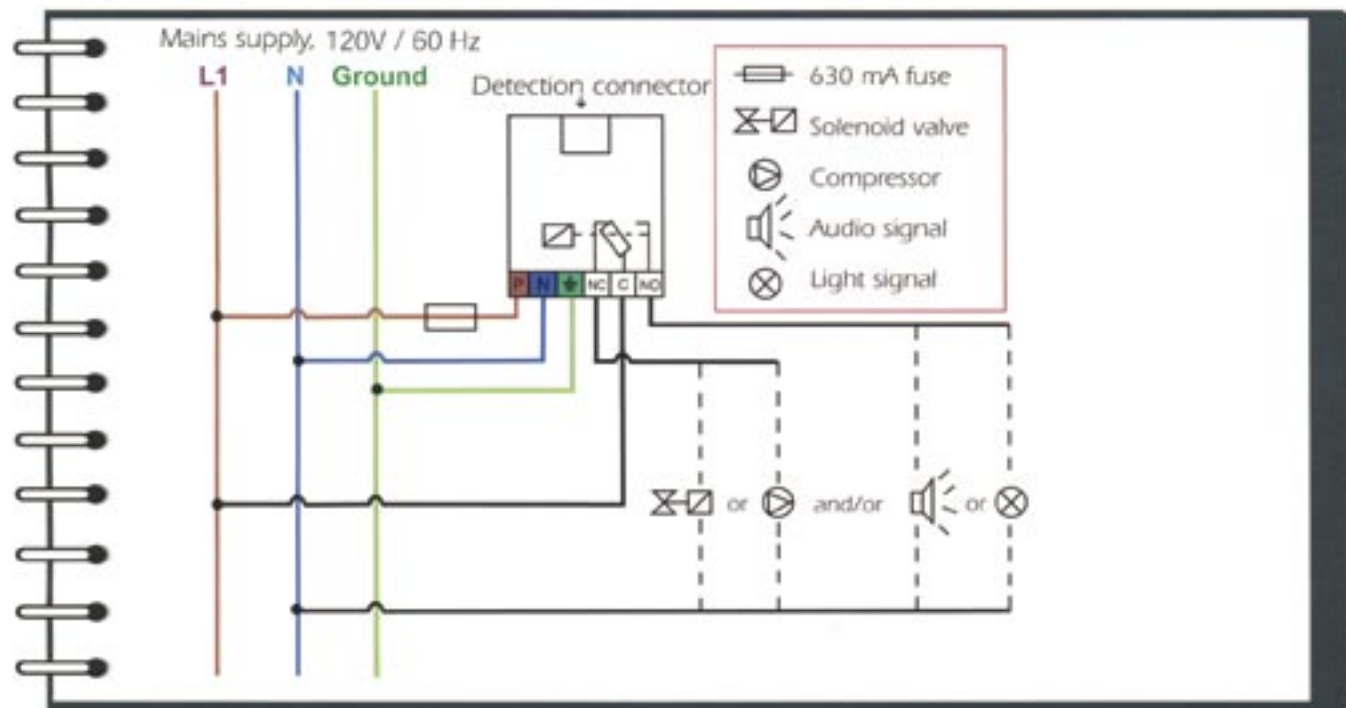

HOW TO INSTALL SAUERMANN SI 1805 & SI 1820 PUMPS



1 • The pump

Dimensions : SI 1805 : L 7.7" xW 5" xH 4.8"
SI 1820 : L 7.7" xW 5" xH 6.7"



⇒ The transport **tear-off strip** is to be removed before starting up.

⇒ The pump receives the condensates via the inlet **in the top**

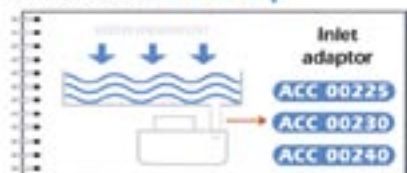

2 • Mechanical assembly

SAUERMANN SI 1805 and SI 1820 have a **UNIQUE reversible tank**

⇒ Condensate inlet **on left**



⇒ Condensate inlet **on right**

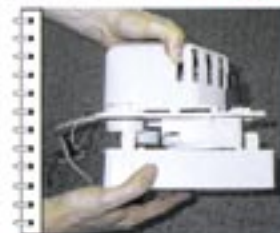

For reasons of compliance with standards, the motor cover (hood) must not be removed

SI 1805 & SI 1820 PUMPS

6• Maintenance



⇒ The inside of the pump must be **regularly** cleaned. For this we recommend that you use a solution containing 5% bleach. Ensure that the float switches remain clean.



7• Removing the valve





IMPORTANT

The pumps must have an electricity supply that is independent to that of the air conditioner to ensure that they continue to operate if the refrigerating appliance breaks down.

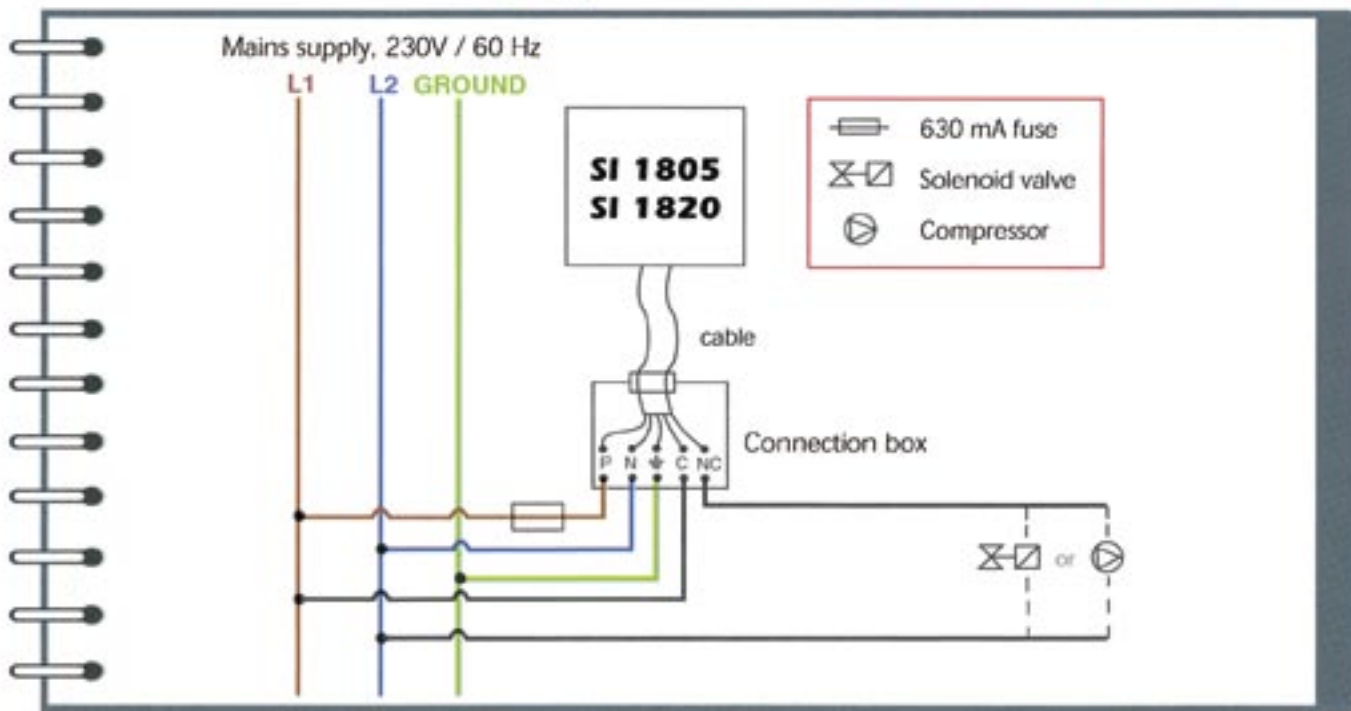

Installation and Connection: SI 1805 & SI 1820 PUMPS 120 V - 60Hz



IMPORTANT

The pumps must have an electricity supply that is independent to that of the air conditioner to ensure that they continue to operate if the refrigerating appliance breaks down.

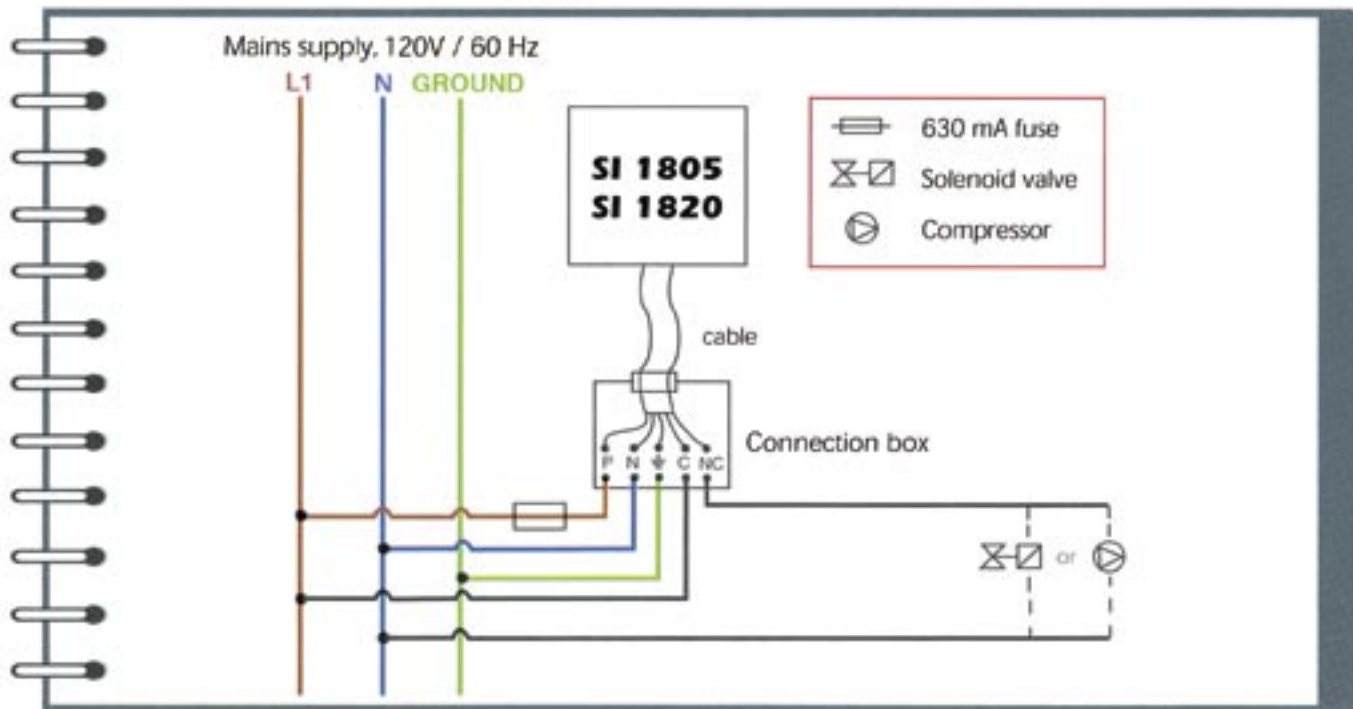

DIFFERENT USES OF THE ALARM

Alarm Contact

SI 3100/3200/1102/1200 :

NC 8 A resistive

SI 1730 : NO - NC 8 A resistive

SI 1805 & SI 1820 : NC 4 A resistive

Chilled water Monosplit and Multisplit

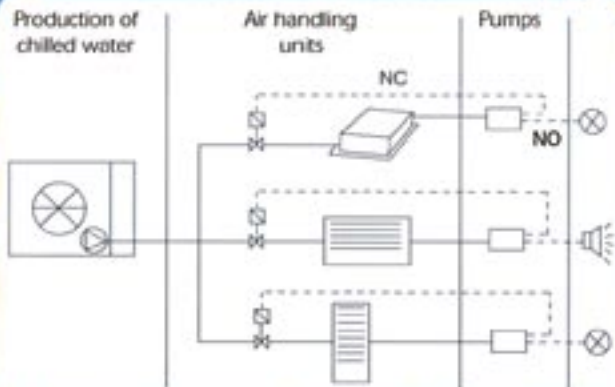

A pump in alarm condition cuts the solenoid valve or sets off an audio or light alarm

Direct expansion Multisplit

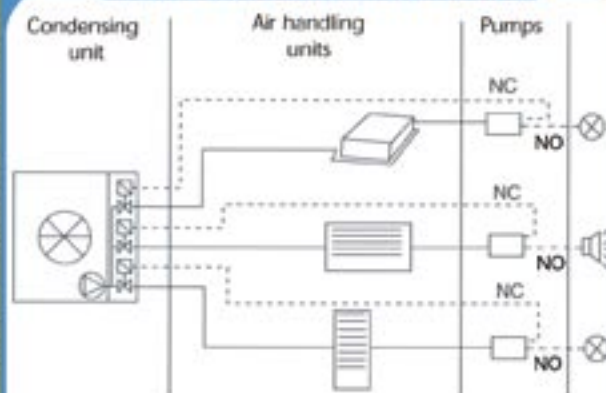

A pump in alarm condition cuts the solenoid valve or sets off an audio or light alarm

Direct expansion Monosplit

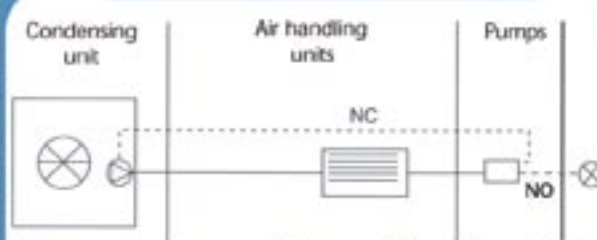

A pump in alarm condition cuts the solenoid valve or sets off an audio or light alarm



SAUERMANNA Corp

300 Vanderbilt Motor Pkwy - Suite 200

Hauppauge - NY 11788 - USA

Phone : (+1) 631 439 6845 - Fax (+1) 631 439 6837

E-mail: sales@sauerermann.us - web site: www.sauerermann.us

We reserve the right to make any technical modifications to the products herein at any time without prior notice.